

## Capative Active Balancer (EK-CxxS5A)

### Product Datasheet

Product Name	Capacitive Active Balancer
Product Model	CxxS5A
Version	V1.0
Adapt Battery String	3S-21S
Adapt Battery Type	NCM/ LFP/LTO
Adapt Battery Capacity	30AH-300AH
Effective date	15th.Dec.2023

Product change history			
Version	Date	Change point description	Approve
V1.0	2023-12-15	Initial version	

Website	<a href="http://www.powerdogbms.com">www.powerdogbms.com</a>
Mobile No.	+86 13612992617
Address	Room 519, Block A, Jiada R&D Building, No. 5 Songpingshan Road, Songpingshan Community, Xili Street, Nanshan District, Shenzhen

---

# Contents

<b>1. Overview .....</b>	<b>1</b>
<b>2. Product model represent method .....</b>	<b>1</b>
<b>3. Technical Parameters .....</b>	<b>1</b>
<b>4. Product List .....</b>	<b>2</b>
<b>5. Product description .....</b>	<b>6</b>
1) Product appearance.....	6
2) Accessories.....	6
3) PCB specifications.....	7
<b>6. Product wiring diagram .....</b>	<b>7</b>
1) Single board wiring diagram .....	7
2) Wiring PIN Definition .....	7
3) Wiring precautions.....	8
<b>7. Cascade wiring diagram .....</b>	<b>8</b>
1) Cascade wiring diagram.....	8
2) Precautions for cascading.....	10
<b>8. Applicable battery type switching &amp; external switch instructions.....</b>	<b>11</b>
1) Applicable battery type switching instructions .....	11
2) External switch instructions.....	11
<b>9. Product indicator light description.....</b>	<b>11</b>
<b>10. Environmental substance requirements .....</b>	<b>11</b>
<b>11. Safety protection measures, transportation and storage.....</b>	<b>12</b>
1) Safety protection measures .....	12
2) Packaging and shipping .....	12
3) Storage .....	12

## 1. Overview

- ①. This series of capacitive active balancing boards is a balancing management system tailor-made for 30AH-300AH capacity series battery packs.
- ②. Patented balancing architecture Fit capacitor method (Patent No.: ZL 2019 1 1259513.3), the capacitor Fit transfers the charge porter, and the entire battery pack participates in energy transfer and active balancing at the same time. 24-hour uninterrupted overall balancing, no external power supply is required, and the entire group is balanced by relying on the internal energy transfer of the battery, with ultra-low loss.
- ③. The maximum balancing current of this series of capacitive active balancing boards is 5.5A. The voltage difference is positively related to the balancing current. Suitable for mainstream ternary lithium batteries, lithium iron phosphate batteries, and lithium titanate batteries on the market. Supports 3 to 21 battery strings. Supports cascade use.
- ④. It is mostly used in large-capacity battery PACKs for outdoor energy storage, home energy storage, industrial and commercial energy storage, RV modification, low-speed vehicles, solar photovoltaics and other products. It can also be temporarily used for battery balancing maintenance, repair and other occasions. It mainly plays the role of repairing the battery pack voltage, restoring the battery pack capacity, and extending the battery pack life.

## 2. Product model represent method

### **EK - C 3S 5A**

① ② ③ ④

No.	Meaning	Represent
①	International trademark abbreviation	Powerdog
②	Product series code	Capacitive balancing board
③	Suitable number of battery strings	Suitable for battery packs with 3 single cells connected in series
④	Maximum balancing current	5 A

## 3. Technical Parameters

Product Name	EK-CxxS5A
Adapt String	3S-21S
Adapt Battery Type	Ternary lithium NCM/iron lithium LFP Lithium Titanate LTO (Jumper Select)
Adapt battery capacity	30AH-300AH
Cell Voltage Working Range	Ternary/lithium iron battery (NCM/LFP): 2.7-4.2V Lithium titanate battery (LTO): 1.8-4.2V
Cascading	Support
Voltage Balancing Accuracy	5mV (typical value)



3	EK-C5S 5A	4S 5S	L69*W58*T16 mm 70g		
4	EK-C6S 5A	4S 5S 6S	L69*W69*T16 mm 85g		
5	EK-C7S 5A	5S 6S 7S	L80*W69.5*T1 6mm 95g		
6	EK-C8S 5A	6S 7S 8S	L91*W70*T16 mm 105g		
7	EK-C10 S5A	8S 9S 10S	L114*W70*T1 6mm 130g		

<p>8</p>	<p>EK-C12 S5A</p>	<p>9S 10S 11S 12S</p>	<p>L137*W70*T1 6mm 160g</p>		
<p>9</p>	<p>EK-C14 S5A</p>	<p>9S 10S 11S 12S 13S 14S</p>	<p>L125*W80*T1 6mm 180g</p>		
<p>10</p>	<p>EK-C16 S5A</p>	<p>12S 13S 14S 15S 16S</p>	<p>L125*W91*T1 6mm 205g</p>		

<p>11</p>	<p>EK-C17 S5A</p>	<p>13S 14S 15S 16S 17S</p>	<p>L125*W103*T 16mm 225g</p>		
<p>12</p>	<p>EK-C21 S5A</p>	<p>17S 18S 19S 20S 21S</p>	<p>L145*W130*T 16mm 250g</p>		

## 5. Product description

### 1) Product appearance

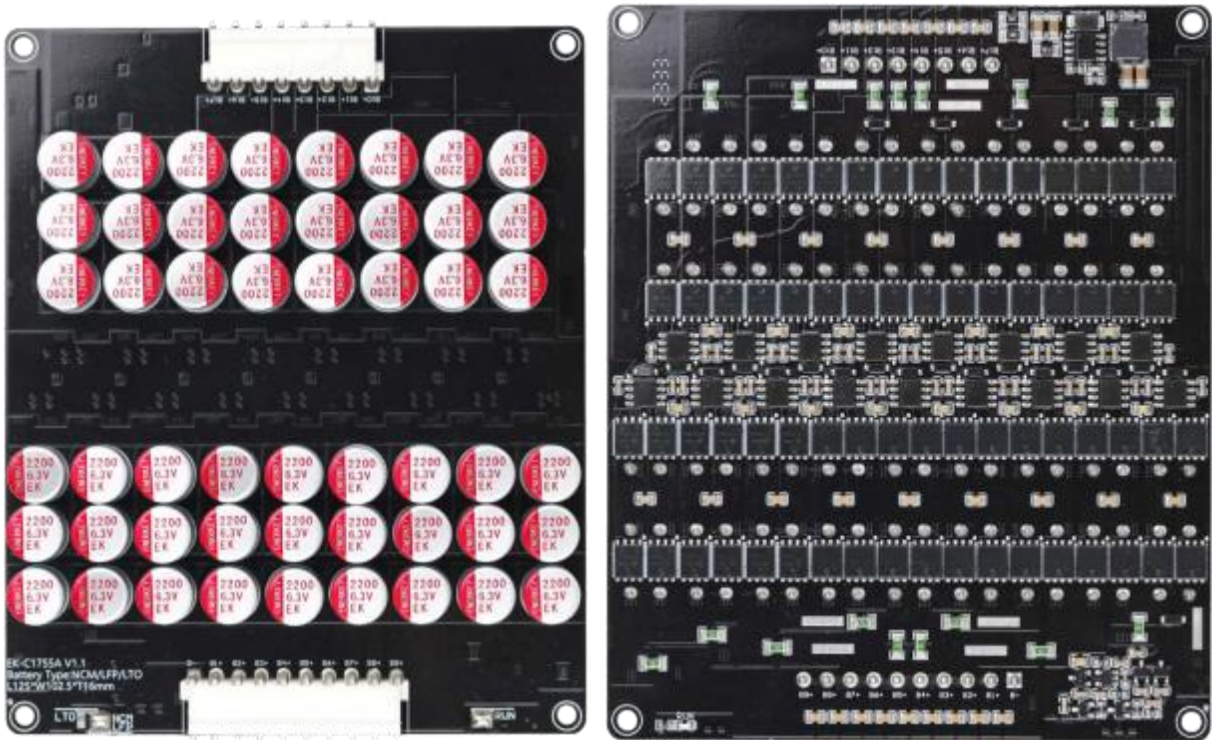

- ①. This product has components on both sides, please pay attention to insulation when using it.
- ②. All shipped products are coated with three-proof paint.
- ③. The diameter of the PCB mounting screw hole is 3.2mm.

### 2) Accessories

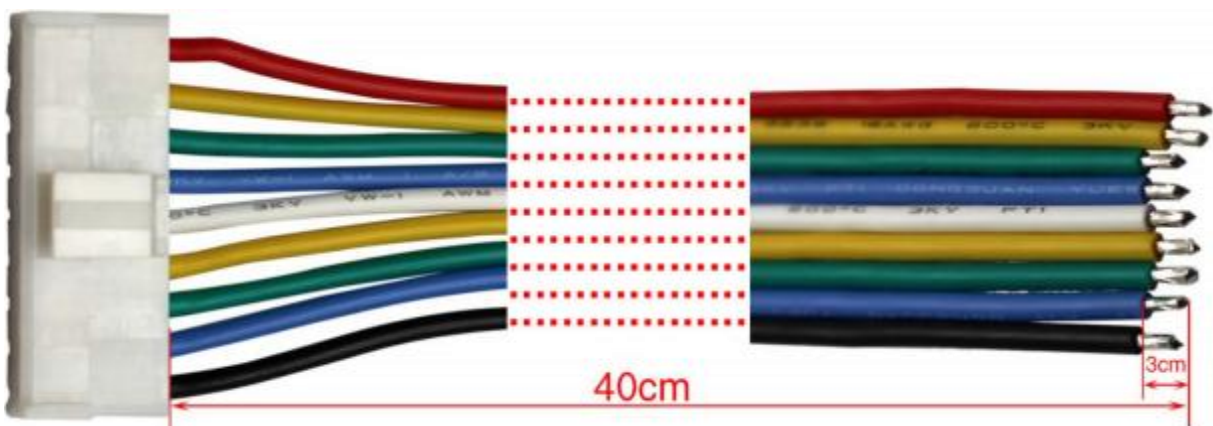

Accessories specifications				
Terminal specifications	Material	Wire number	Wire length	Stripping length
VH3.96mm	Cu	18AWG	40cm	3cm

### 3) PCB specifications

PCB Specifications			
Material	FR-4	Layer	4 layer
PCB thickness	0.6±0.10	Copper(CU) thickness	2.0 oz
Pads plating	Lead-free spray tin	Plate thickness	
Solder	Black	Silkscreen	White

## 6. Product wiring diagram

### 1) Single board wiring diagram

Taking 21S as an example, the wiring diagram is shown in Figure 4.1.1. If you need wiring diagrams for other models, please check the product specifications

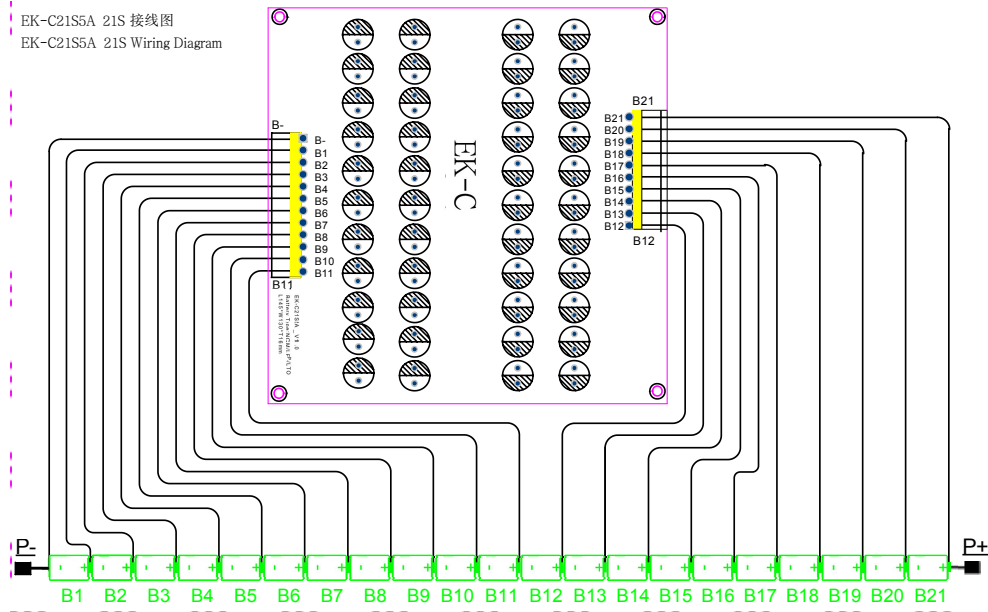

### 2) Wiring PIN Definition

Pin Silkscreen	Definition
B-	Negative pole of the 1st battery string
B1	Positive pole of the 1st battery string
B2	Positive pole of the 2nd battery string
.....	.....
B20	Positive pole of the 23th battery string
B21	Positive pole of the 24th battery string

### 3) Wiring precautions

- ①. This product requires welding operation for assembly. Please strictly follow the wiring diagram! If you have any questions during the assembly process, please contact after-sales personnel;
- ②. During assembly, please first weld the terminal wire to the battery pack, and then insert the terminal wire into the product;
- ③. The cable plugs with more than 13 strings need to be inserted obliquely, first contact the B-pin and insert it upward obliquely, otherwise it may cause the board to burn.
- ④. After connecting the battery, please pay attention to the insulation protection of the product to avoid short circuit when powered on.
- ⑤. When a single board is used and there are spare pins, the spare pins are left hanging. For example, when 21S is connected to a 20S battery pack, "B21" is left hanging. For details, please refer to the corresponding model specification.

## 7. Cascade wiring diagram

### 1) Cascade wiring diagram

- ①. Usage of an "energy exchange common terminal" (basic usage)

Take 2PCS "EK-C16S5A" used in a 33S battery pack as an example, the wiring diagram is shown in Figure 5.1.1.

If you need other serial wiring diagrams, please contact sales staff for them.

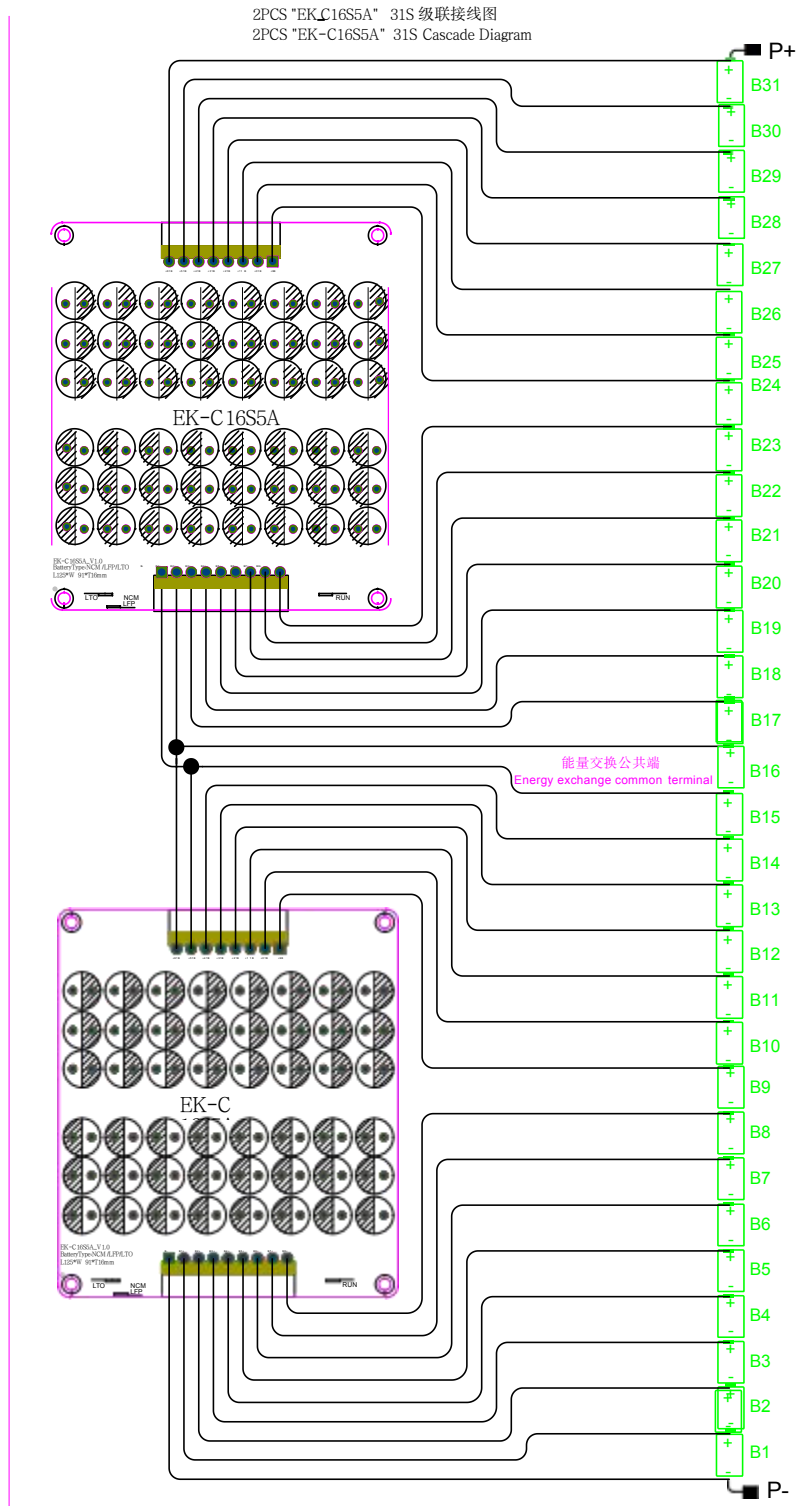

Figure 5.1.1.

②. Usage of more than one "energy exchange common terminal" (advanced usage)

The advantage of more than one "energy exchange common terminal" is that the balancing efficiency will be higher.

The following takes 2PCS "EK-C16S5A" used in a 26S battery pack as an example, and the wiring diagram is shown in Figure 5.2.1.

2PCS "EK\_C16S5A" 26S级联接线图  
 2PCS "EK-C16S5A" cascade to 26S wiring diagram

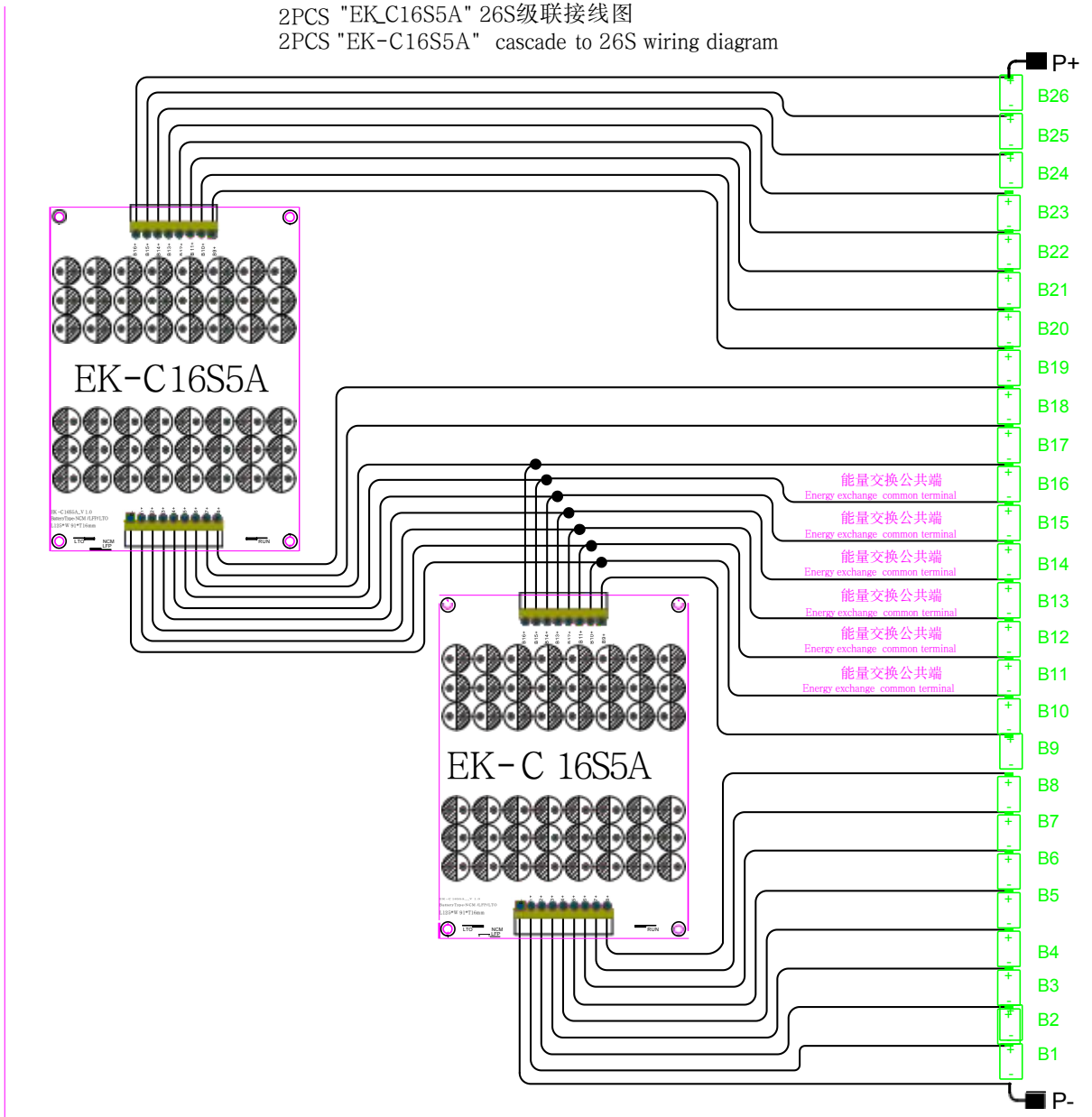

Figure 5.1.1.

## 2) Precautions for cascading

①. When using cascade, there is at least one "energy exchange common terminal" between every two balancing boards

When welding, please pay attention to whether the connection here is correct and whether there is any phenomenon such as false welding.

②. The cascade use method of one "energy exchange common terminal" and more than one "energy exchange common terminal" is feasible.

It is recommended to use the cascade method of one "energy exchange common terminal", which is relatively simple to operate.

③. The cascade use is a high-voltage use environment, please take personal protection.

Please check the wiring repeatedly for errors. Wrong wiring will cause the board to burn out.

If it cannot be used after connection, please contact after-sales personnel to consult the corresponding cascade wiring diagram.



## 8. Applicable battery type switching & external switch instructions

### 1) Applicable battery type switching instructions

Illustration:



This balancing board is suitable for NCM ternary lithium and LFP lithium iron batteries by default. The applicable battery type can be changed by jumper welding, and the battery type can be selected according to the "1", "2", and "3" pads in the picture above;

Applicable battery type	Pad number in the picture	Physical illustration	Remark
LTO Lithium titanate	1+2 connect (Illustration frame ①)		Customers need to weld and switch by themselves
NCM ternary lithium LFP Lithium iron	2+3 connect (Illustration frame ②)		Factory default mode

### 2) External switch instructions

" Illustration frame ③" can be connected with an external switch to control the opening and closing of equalization.

The factory default is to connect the battery pack and automatically turn on balancing.

## 9. Product indicator light description

Indicator status	Product operation status
Always on	Balance at work
Extinguish	Under voltage sleep

## 10. Environmental substance requirements

Each battery corresponds to an LED indicator, and you can clearly observe whether each cell is balanced.

Harmful Substance	Limit standard (mg/kg)
Lead (Pb)	1000
Cadmium (Cd)	100
Mercury (Hg)	1000
Hexavalent chromium (Cr6+)	1000
Polybrominated biphenyls (PBB)	1000
Polybrominated diphenyl ethers (PBDE)	1000

## 11. Safety protection measures, transportation and storage

### 1) Safety protection measures

- ①. There is no high voltage in the balancing board itself, and it will not cause electric shock damage to the body.
- ②. Do not repair the balancing board while the power is on. All repairs should be performed by qualified service personnel.  
If the working voltage set by the factory is changed, the safety certificate no longer applies.
- ③. When using, please pay attention to the insulation treatment of the product to avoid short circuit.
- ④. Pay attention to ESD protection when using this product.
- ⑤. This product complies with the company's thrust standards: 0402 components  $\geq 1.0\text{KgF}$ ; 0603 components  $\geq 1.5\text{KgF}$ ; IC and MOS tubes  $\geq 2.0\text{KgF}$ .

### 2) Packaging and shipping

- ①. Separate and package PCBA with anti-static bubble bags.
- ②. The packed products can be transported by ordinary means of transportation when they are not directly affected by rain, snow or violent collisions and bumps.

It is not allowed to be placed together with corrosive substances such as acids and alkalis during transportation.

### 3) Storage

Packaged products should be stored in a permanent warehouse with a temperature of  $0^{\circ}\text{C}\sim 35^{\circ}\text{C}$  and a relative humidity of no more than 80%.

The warehouse should be free of acid, alkali and corrosive gases, strong mechanical vibration and impact, and no strong magnetic field.